

CZM

FOUNDATION EQUIPMENT



EK125HH

**ON CAT323
(NEXT GEN)**

EK125HH

Mounted on
CAT323
(NEXT GEN)



Very efficient to drive sheet piles with minimum disturbance.

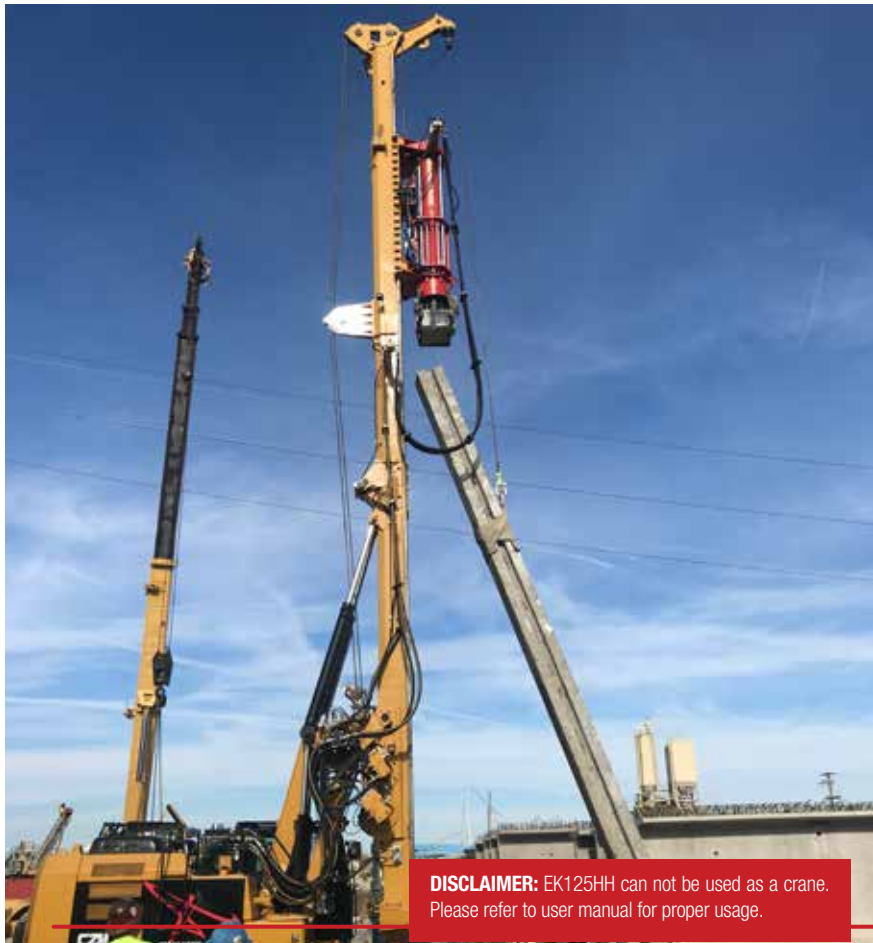

DISCLAIMER: EK125HH can not be used as a crane. Please refer to user manual for proper usage.



High performance on concrete pile driving

APPLICATION & TECHNICAL SPECIFICATIONS

The **EK125HH** is a hydraulic pile driving rig mounted on CAT323 Next Gen base unit. This rig is equipped with a 4 ton (3.6 m.ton) free fall hydraulic impact hammer. The hammer's free fall feature has many advantages:

- Operated by gravity = half as much maintenance over the hammer's life cycle.
- Less power required of the carrier unit = a lower horsepower requirement and less fuel consumption.
- No need for a rebound ring = greater durability no matter what is your specification for bearing capacity even if you're driving to refusal.
- Better rate ratio between piston weight and total hammer weight = higher energy from a smaller rig.
- Two external lift cylinders = controlled height, quick and easy to visually inspect and access for maintenance.

EK125HH is a self-erecting compact one-load rig = easy transport and quick set up for operation.

HYDRAULIC HAMMER MONITORING SYSTEM

- Accurate laser height control;
- Remote access and online tracking;
- Touch screen or mouse operation;
- Special support for PDA test.



TECHNICAL SPECIFICATIONS

LEADER

Overall height	63 ft	19 m
Hammer stroke	46 ft	14 m
Max Pile Length (Standard)	45 ft	13.7 m
Max Pile Length (Long Mast)	50 ft	15.4 m
Max Pile Diameter	20 in	500 mm
Parallelogram reach stroke	7 ft	2.13 m

HYDRAULIC HAMMER – HH 3600

Piston weight	8,000 lb	3,600 kg
Hammer total weight	14,600 lb	6,600 kg
Blows per minute	0 – 80 1/min	0 – 80 1/min
Drop Height	0 – 4 ft	0 – 1.2 m

HYDRAULIC HAMMER – HH 5000

Piston weight	11,000 lb	4,989 kg
Hammer total weight	17,600 lb	7,983 kg
Blows per minute	0 – 80 1/min	0 – 80 1/min
Drop Height	0 – 4 ft	0 – 1.2 m

MAIN WINCH

Max. pull-force	40,400 lbf	18,400 kgf
Line speed	200 ft/min	60 m/min
Cable diameter	-	24 mm
Drum diameter - 1st layer	18.5 in	465 mm

AUXILIARY WINCH

Max. pull-force	22,000 lbf	10,000 kgf
Line speed	180 ft/min	55 m/min
Cable diameter	¾ in	-
Drum diameter - 1st layer	16.5 in	420 mm

MAST INCLINATION

Backward	15°	15°
Forward	9°	9°
Sideways	9°/9°	9°/9°

DIESEL ENGINE CAT323 NEXT GEN (CAT C6.6 ACERT)

Gross Power – SAE J1995	164 hp	122 kw
Displacement	403 in ³	6,6 L
Fuel Tank	108 gal	410 L

HYDRAULIC SYSTEM (CAT323 NEXT GEN)

Hydraulic Pressure	5,076 psi	350 bar
Flow rate (main circuit)	2x49 gal/min	2x185 L/min
Flow rate (auxiliary circuit)	14.3 gal/min	54 L/min
Pilot circuit pressure	569 psi	40 bar
Pilot circuit flow	6.4 gal/min	24.3 L/min
Hydraulic oil tank capacity	37.8 gal	143 L

UNDERCARRIAGE

Track length	15 ft 2 in	4,610 mm
Length to center of rollers	12 ft 7 in	3,830 mm
Transport position width (retracted)	8 ft 4 in	2,560 mm
Working position width (extended)	11 ft 10 in	3,600 mm
Shoes width	23.6 in	600 mm
Max. travel speed	1.93 mph	3.1 km/h

TRANSPORT

Transport height	10 ft 11 in	3,315 mm
Length (Standard)	49 ft	15 m
Length (Long Mast)	51 ft	15.6 m
Transport width	9 ft	2,750 mm
Transport weight with hammer (Standard)	90,000 lb	41,000 kg
Transport weight with hammer (Long Mast)	95,000 lb	43,000 kg
Hammer weight	14,600 lb	6,600 kg
Transport weight without hammer	75,400 lb	34,400 kg

GENERAL DIMENSIONS STANDARD VERSION

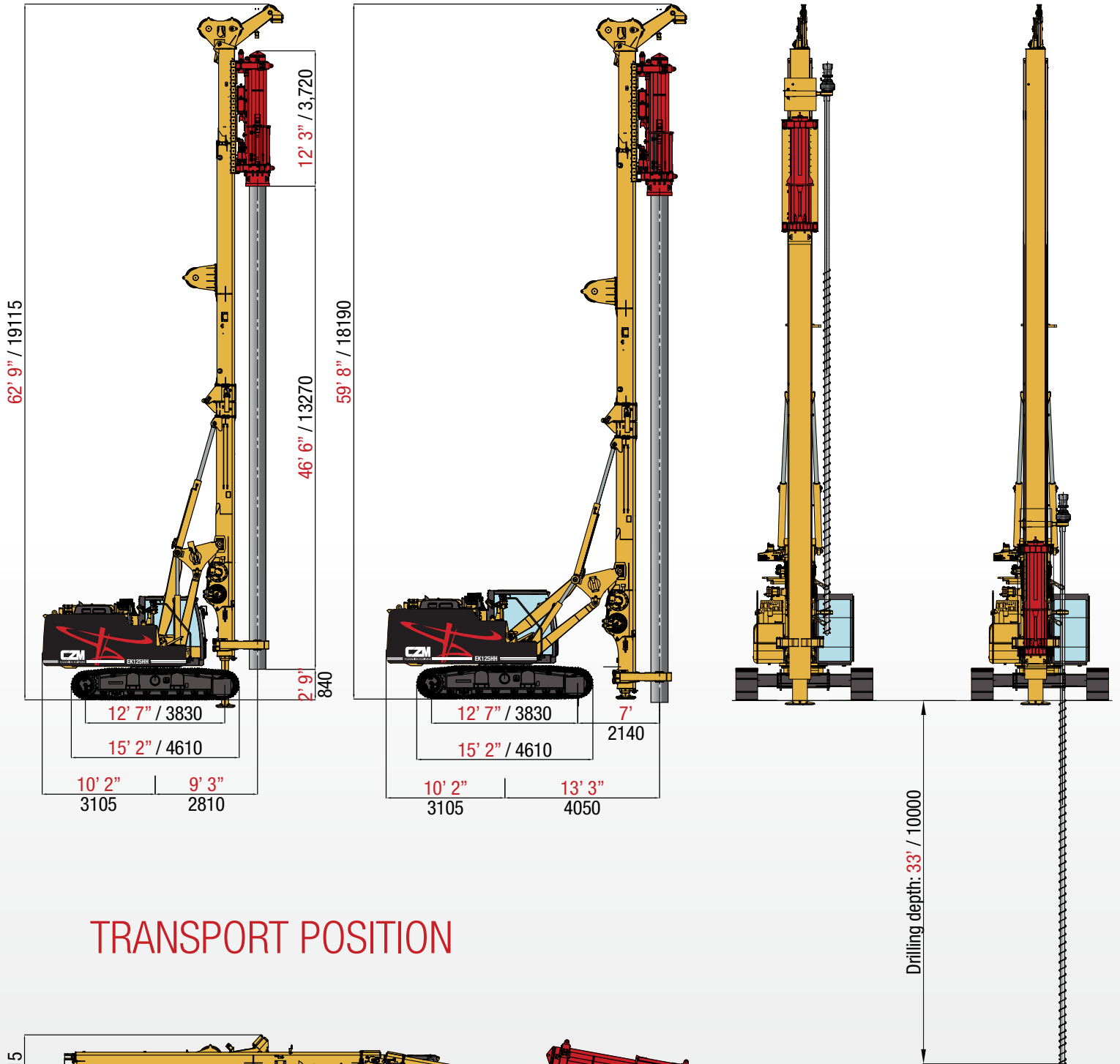

TRANSPORT POSITION

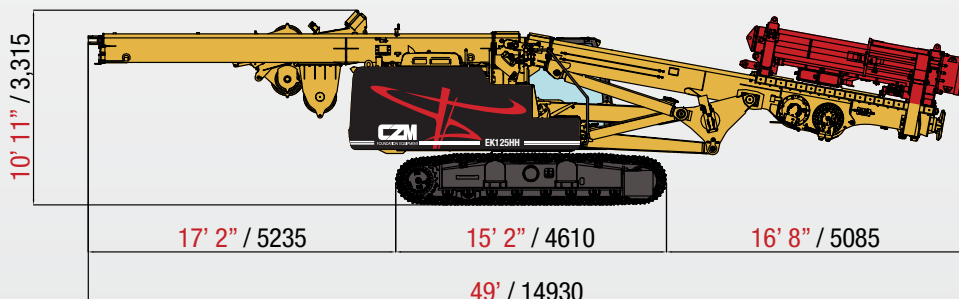

GENERAL DIMENSIONS LONG MAST & HAMMER

69' 3" / 21.095

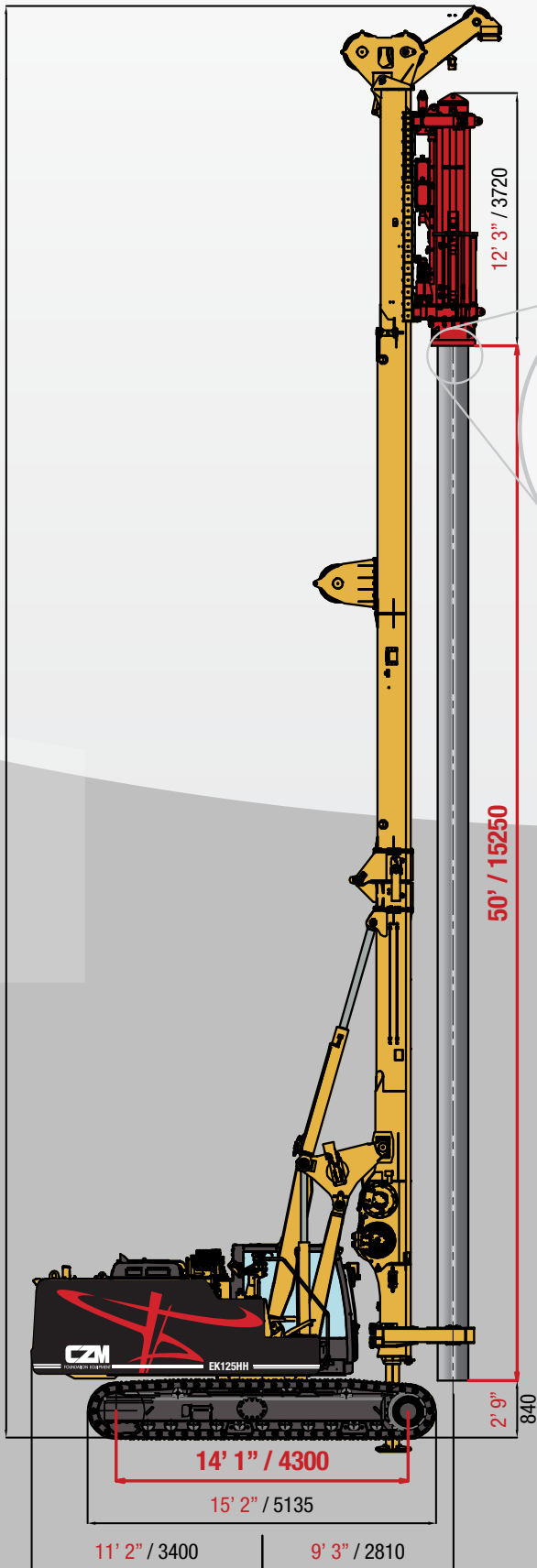

PILE CAP

The pile caps are designed and manufactured according to the customer need.

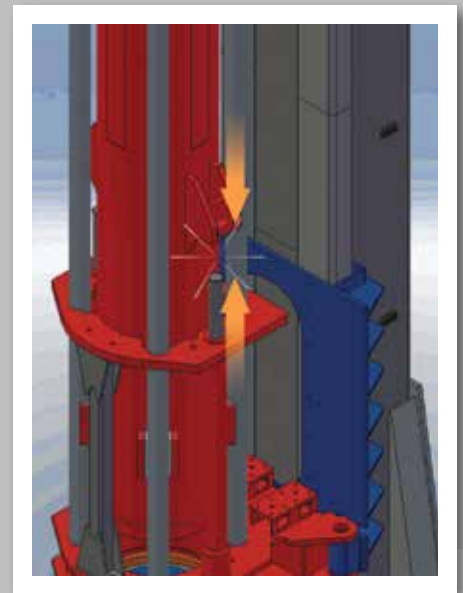
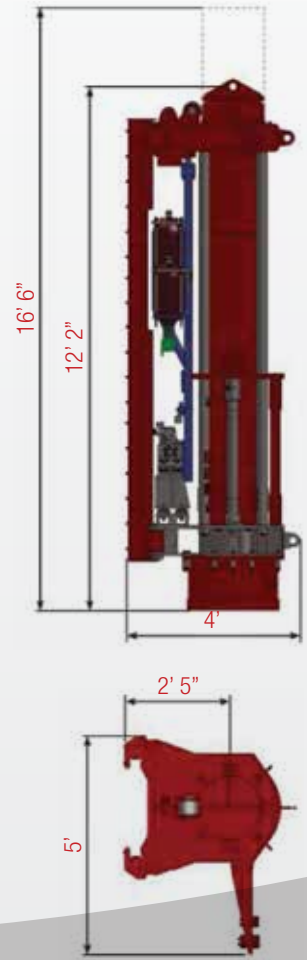
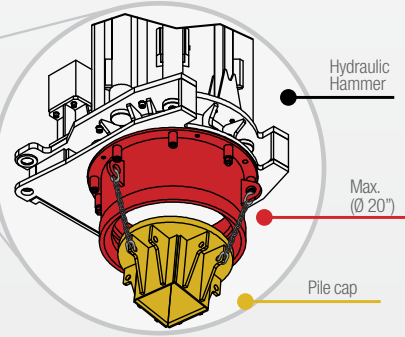

EXCLUSIVE SAFETY MODE

When activated, the Safety mode on MHControl+ can prevent the major cause of cylinder premature wear-off: the mechanical shock between the drive cylinder arm and the weight.

Eccentric caps to drive piles facing the wall



Driving 50 ft timber pile



Very compact hydraulic hammer



One load transport with quick set up





FOUNDATION EQUIPMENT

THE COMPANY

CZM is headquartered in Savannah, Georgia, USA. For over 40 years, we have specialized in manufacturing foundation equipment. We design and customize models for many different drilling applications including Drill shafts, CFA/cased CFA, Micropile and anchoring, piledrive and hydraulic hammers and soil improvements. We are a Caterpillar OEM (Original Equipment Manufacturer).

HEADQUARTERS

962 Interstate Centre Boulevard
Ellabell • Georgia • 31308
United States • Phone: (912) 200-7654

AFTER SALES - GEORGIA

145 East Industrial Boulevard
Pembroke • Georgia • 31321
United States • Phone: (912) 200-7654

AFTER SALES - TEXAS

2501 Blue Mound Rd. W
Haslet • Texas • 76052
United States • Phone: (817) 232-8053

WWW.CZM-US.COM